



HARDWARE SELECTION FOR HOLLOW METAL DOORS AND FRAMES



DISCLAIMER

This manual was developed by representative members of the Hollow Metal Manufacturers Association Division (HMMA) of the National Association of Architectural Metal Manufacturers (NAAMM) to provide information and guidance on the selection of hardware for hollow metal doors and frames. This manual contains advisory information only and is published as a public service by NAAMM and its HMMA Division. NAAMM AND ITS HMMA DIVISION DISCLAIM ALL LIABILITY OF ANY KIND FOR THE USE, APPLICATION OR ADAPTATION OF MATERIAL PUBLISHED IN THIS STANDARD.

National Association of Architectural Metal Manufacturers
8 South Michigan Avenue • Chicago, Illinois 60603 • 1-312-332-0405
Fax 1-312-332-0706 • Web Site: www.naamm.org

TABLE OF CONTENTS

Part 1 – INTRODUCTION	1
Part 2 – HANGING DEVICES	2
A. BUTT HINGE	2
1. Full Mortise	2
2. Half Mortise	2
3. Half Surface	2
4. Full Surface	2
B. CONTINUOUS HINGE	3
1. Edge	3
2. Half Surface	3
3. Half Edge	3
4. Full Surface	3
C. ANCHOR HINGE	4
D. THRUST PIVOT UNIT AND HINGE SET	4
E. PIVOT REINFORCED HINGE	4
F. PIVOT	5
1. Offset	5
2. Center	5
3. Pocket	5
G. HOSPITAL “SWING CLEAR” HINGE	6
1. Full Mortise	6
2. Half Mortise	6
3. Half Surface	6
4. Full Surface	6
H. INVISIBLE HINGE	7
Part 3 – SECURING DEVICES	8
A. LOCKS, LATCHES, AND DEADLOCKS	8
1. Mortise Lock	8
2. Mortise Deadlock	8
3. Cylindrical Lock	8
a. Bored	8
b. Thru-Bolted	9
4. Cylindrical Deadlock, Bored	9
5. Unit Lock	9
6. Hospital Latch	9

B.	PANIC / FIRE EXIT HARDWARE	10
1.	Mortise and Rim	10
2.	Vertical Rod	10
C.	BOLTS	11
1.	Flush	11
a.	Manual	11
b.	Self-Latching	11
c.	Automatic	11
2.	Surface	11
Part 4 -	CLOSING AND CONTROLLING DEVICES	12
A.	CLOSERS	12
1.	Overhead	12
2.	Floor	13
B.	DOOR COORDINATORS	13
Part 5 -	STOPS AND HOLDERS	14
A.	DOOR STOPS	14
1.	Floor and Wall	14
2.	Overhead	14
B.	EMERGENCY DOOR STOPS	15
C.	OVERHEAD DOOR HOLDERS	15
Part 6 -	MISCELLANEOUS	16
A.	GASKETING / WEATHERSTRIPPING	16
B.	DOOR BOTTOMS	16
1.	Mortise	16
2.	Surface	16

HARDWARE SELECTION FOR HOLLOW METAL DOORS AND FRAMES

PART 1 - INTRODUCTION

The hardware used not only determines how well a door functions, but is also an important factor in the working life of the opening. Among the many benefits of custom hollow metal is the virtually unlimited choice of hardware that can be used. The architect is free to select those items which will provide the operational features, aesthetics, and quality desired, such as the use of electrical hardware, pivots or anchor hinges, concealed closers, concealed vertical rod devices, separate deadlocks, pre-assembled locks, and other architectural hardware.

For any hardware item to function properly, the door and/or frame must be properly prepared. The durability of the hardware and its attachment depends on the strength of the preparation. For example, preassembled ("unit") locks cannot be properly installed by simply making a rectangular cutout in the door edge. The type of lock to be used must be known in advance by the door manufacturer so the appropriate reinforcement and preparation can be built into the door. The same is true of all other architectural hardware items.

Field applied hardware preparations cannot compare in strength or quality with factory-made preparations. Since the custom manufacture of hollow metal is designed for a specific purpose, its reinforcing and preparation are within the tolerances specified for the hardware and provide the strength for secure fasteners.

This publication is intended to acquaint the reader with commonly used door hardware that provide both aesthetic appeal and durable function. This summary is not intended as a reference catalog or a comprehensive source of hardware information, but only as an indication of the variety of hardware choices available.

In order to properly prepare each opening for the specified hardware items, a hardware schedule, corresponding templates, and catalog cuts, if appropriate, are required. The hardware schedule must be understandable and accurately relate the specific hardware to the specific opening in a logical manner. Although there are alternate schedule formats, the vertical hardware schedule is most commonly used and preferred.

The vertical schedule lists the exterior openings first, followed by the interior openings, and miscellaneous items last.

The following information is required at the beginning of a hardware schedule:

- A. Job: Name, location, and telephone number.
- B. Architect: Name, location, and telephone number.
- C. Contractor: Name, location, and telephone number.
- D. Hardware Supplier: Name, location, and telephone number.
- E. Door and Frame manufacturer: (if known) Name, location, and telephone number.
- F. Hardware manufacturers' names for all listed items.
- G. Template numbers.
- H. Abbreviations.

WITHIN THE HARDWARE SCHEDULE, ONLY OPENINGS WITH IDENTICAL HARDWARE SHOULD BE LISTED UNDER THE SAME HARDWARE SET.

Each hardware set must include all information required to properly prepare the opening for the hardware.

This includes:

- A. Hardware set number
- B. Opening identification and location
- C. Door and frame material
- D. Door and frame dimensions
- E. Hand of door
- F. Special door or frame conditions
 - 1. Degree of opening and hold open
- G. Label requirements
- H. Each hardware item, including;
 - 1. Product description
 - 2. Finish
 - 3. Hand
 - 4. Size
 - 5. Template number
 - 6. Special requirements

The sequence for listing each hardware item is as follows:

- A. Hanging Devices
- B. Securing Devices
- C. Operating Trim
- D. Accessories for Pair of Doors Only
- E. Closing and Controlling Devices
- F. Protective Plates and Trim
- G. Stops and Holders
- H. Accessories
- I. Miscellaneous

THE LOCATION OF HARDWARE ON DOORS AND FRAMES SHALL BE AS SPECIFIED IN THE HOLLOW METAL DOOR AND FRAME SPECIFICATION.

PART 2 - HANGING DEVICES

A. BUTT HINGE

Butt hinges are the most common type of hinge. They are available in two thicknesses, commonly referred to as weights, (regular or heavy) and with or without ball bearings. When provided with ball bearings, regular weight hinges will have two bearings as shown and heavy weight hinges will have four bearings.

Sizes and weight of hinge should be determined by published industry standards.

Standard Height: 4-1/2 in. (114 mm); 5 in. (127 mm) for doors over 36 in. (914 mm) wide.

Standard Width: 4-1/2 in. (114 mm) for 1-3/4 in. (44 mm) door; with 1-1/2 in. (38 mm) trim clearance (see dimension A below); 5 in. (127 mm)(or more) for thicker doors or larger clearances.

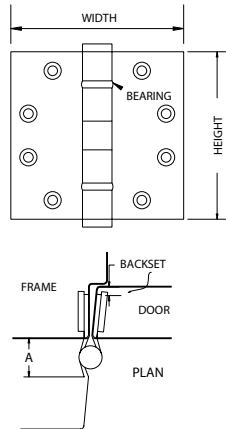

FIGURE 1a
FULL MORTISE

1. The Full Mortise Butt Hinge, Figure 1a, has two equal leaves, one mortised into the door edge and the other mortised into the frame rabbet.

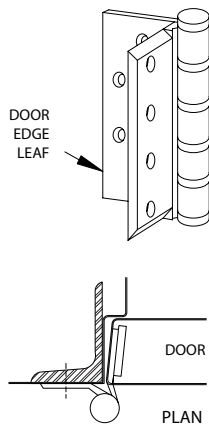

FIGURE 1b
HALF MORTISE

2. The Half Mortise Butt Hinge, Figure 1b, has one leaf mortised into the door edge and one leaf surface mounted on the face of the frame.

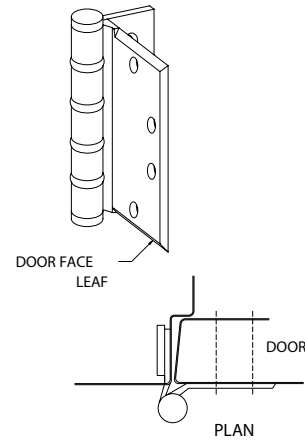

FIGURE 1c
HALF SURFACE

3. The Half Surface Butt Hinge, Figure 1c, has one leaf surface mounted on the face of the door and one leaf mortised into the frame rabbet.

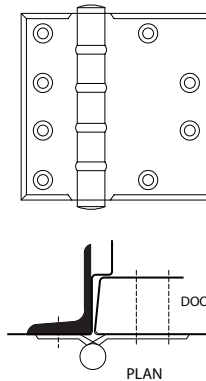

FIGURE 1d
FULL SURFACE

4. The Full Surface Butt Hinge, Figure 1d, has two leaves of differing widths, one surface-mounted on the door face, the other surface mounted on the frame face.

B. CONTINUOUS HINGE

Continuous hinges are surface mounted to both the door/frame edge or face and distribute the load of the door over the entire length of the hinge. They are used where door impact resistance, safety, cleanliness, and adjustability are frequent and necessary requirements. Such places include hospitals and schools.



FIGURE 2a
BARREL and GEAR

Continuous hinges, Figure 2a, are available in two styles, Barrel and Gear Hinge. For illustration purposes only, Figures 2b through 2e are shown with Barrel type hinge.

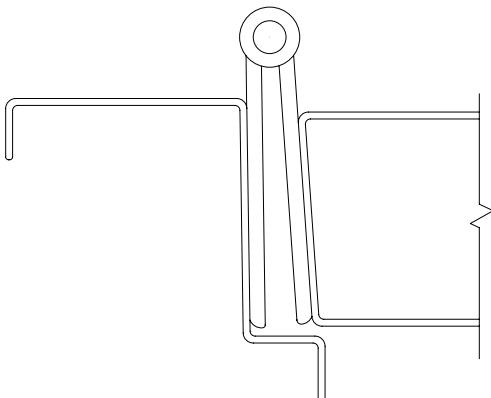

FIGURE 2b
EDGE MOUNTED

1. The Edge Mounted Continuous Hinge, Figure 2b, has two equal leaves; one leaf mounted to the frame rabbet and the other leaf mounted to the door edge.

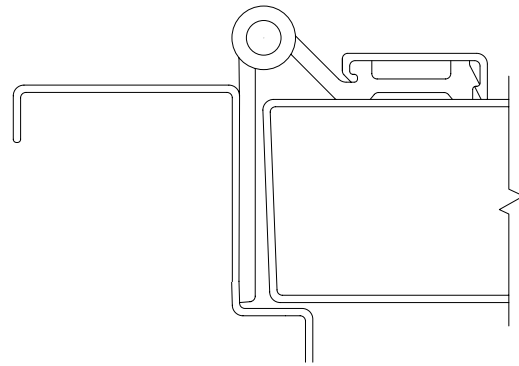

FIGURE 2c
HALF SURFACE

2. The Half Surface Continuous Hinge, Figure 2c, has one leaf mounted to the frame rabbet and the other leaf mounted to the door face.

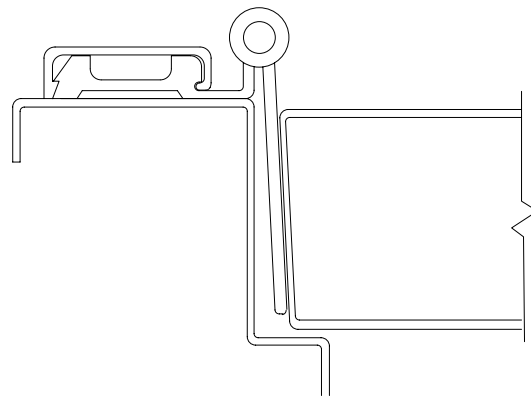

FIGURE 2d
HALF EDGE MOUNTED

3. The Half Edge Mounted Continuous Hinge, Figure 2d, has one leaf mounted to the frame face and the other leaf mounted to the door edge.

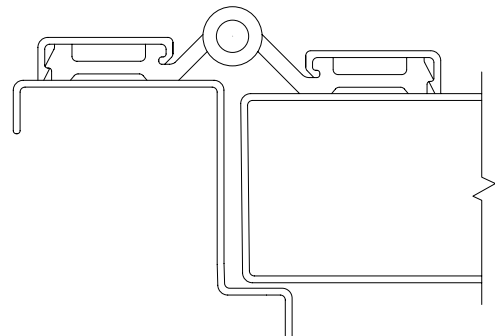

FIGURE 2e
FULL SURFACE

4. The Full Surface Continuous Hinge, Figure 2e has one leaf mounted to the frame face and the other leaf mounted to the door face.

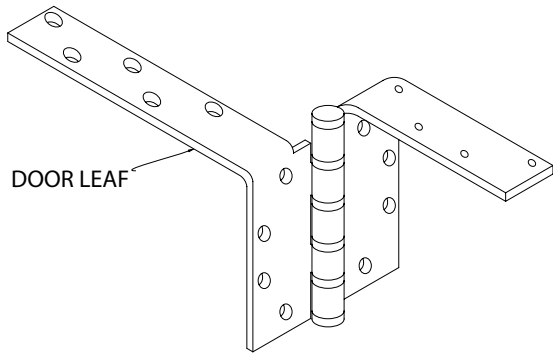

FIGURE 3
ANCHOR HINGE

C. ANCHOR HINGE

The Anchor Hinge, Figure 3, is a heavyweight hinge with each leaf extended at its top edge which is bent to form a flange that fastens to the top edge of the door and to the frame head rabbet. It is used as a top hinge on heavy doors and doors having high frequency usage.

Anchor and pivot type hinges should be specified for heavy doors and doors with high frequency use, such as entrances to large department stores, office buildings, theaters, banks, schools, or to lavatories. They are available for beveled or square edge doors.

DUE TO HARDWARE MANUFACTURING DESIGN VARIATIONS WITH ANCHOR HINGES, THRUST PIVOTS, AND PIVOT REINFORCED HINGES, DRILLING AND TAPPING SHALL BE DONE IN THE FIELD BY THE CONTRACTOR.

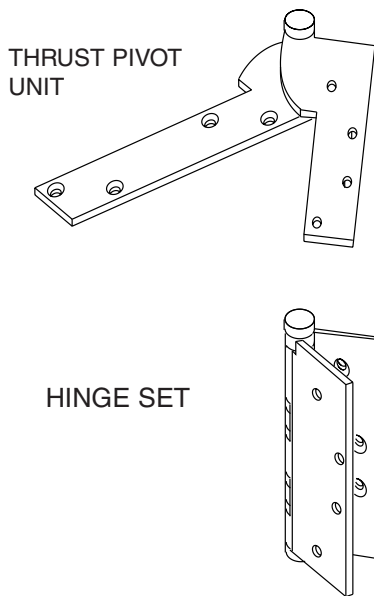

FIGURE 4
THRUST PIVOT UNIT AND HINGE SET

D. THRUST PIVOT UNIT AND HINGE SET

The Thrust Pivot Unit and Hinge Set, Figure 4, are mounted at the top of the door and frame, with both jamb and top plates for both door and frame. They are used with conventional butt hinges on wide doors that may be subjected to normal abuse. The thrust pivot unit is almost invisible when the door is closed.

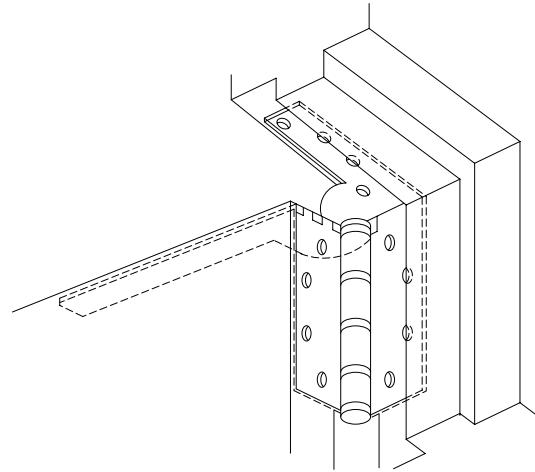

FIGURE 5
PIVOT REINFORCED HINGE

E. PIVOT REINFORCED HINGE

The Pivot Reinforced Hinge, Figure 5, is a heavy weight hinge with an added pivot on the same pin. Leaves of the pivot are interlocked with hinge leaves. It is used with conventional butt hinges on doors subject to abnormal abuse, particularly with overhead closers.

F. PIVOT

Pivots are stronger and more durable than hinges. They are better able to withstand the racking stresses to which doors are subjected. Their use is generally recommended on oversized, heavy doors such as lead-lined doors, and public entrances to schools, theaters, banks, stores, and office buildings.

BECAUSE OF ADJUSTMENTS THAT MUST BE MADE DURING THE INSTALLATION OF DOORS WITH BOTTOM PIVOTS, DRILLING AND TAPPING SHALL BE DONE IN THE FIELD BY THE CONTRACTOR.

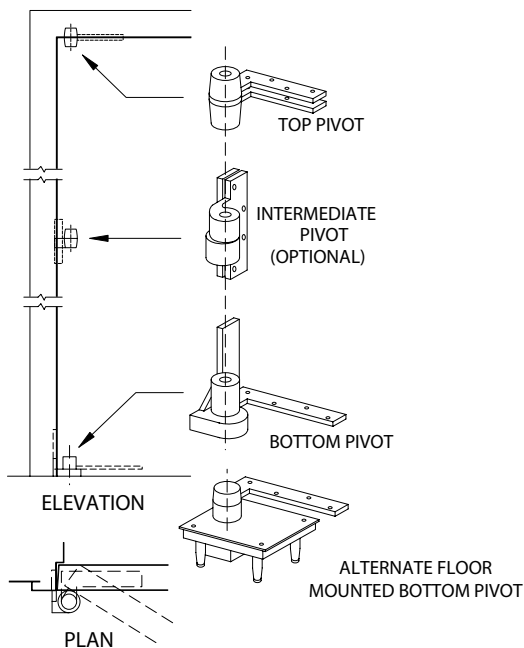

FIGURE 6a
OFFSET

1. The Offset Pivot, Figure 6a, is only used on single-acting doors. Need for the intermediate pivot depends upon the size, weight, and usage of the door. Recommendation of hardware manufacturer should be followed. Pivot knuckles are visible when door is closed.

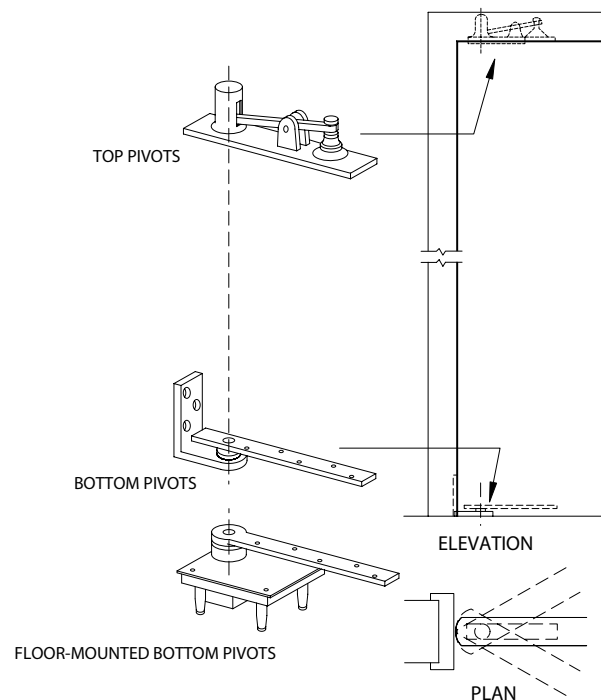

FIGURE 6b
CENTER

2. The Center Pivot, Figure 6b, is used at the top and bottom of double-acting doors only. Pivots are completely invisible when the door is closed.

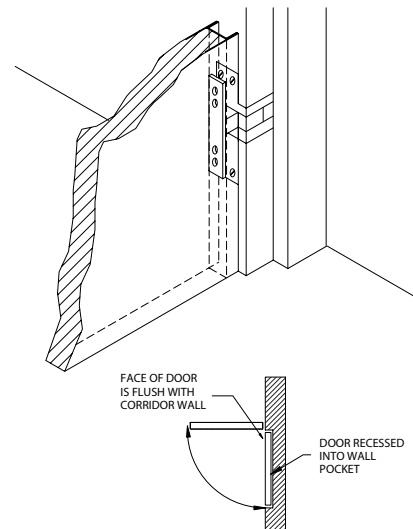

FIGURE 6c
POCKET

3. Pocket Pivot, Figure 6c, Frame leaves are fully mortised and door leaves are semi-concealed, which allows a wider clear opening width than conventional hinges.

G. HOSPITAL “SWING CLEAR” HINGE

The hinge pins are located approximately 2 in. (51 mm) beyond the door edge, providing an unobstructed clear frame opening width when the door is open at 90 degrees. They are used on hospital corridor doors to patient, operating, emergency rooms, or wherever a completely clear opening is required.

Swing clear hinges are available only in heavy weight.

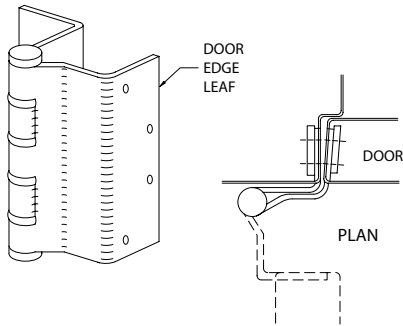

FIGURE 7a
FULL MORTISE

1. The Full Mortise Hospital Hinge, Figure 7a, has one leaf mortised into the frame rabbet and the other mortised into the door edge.

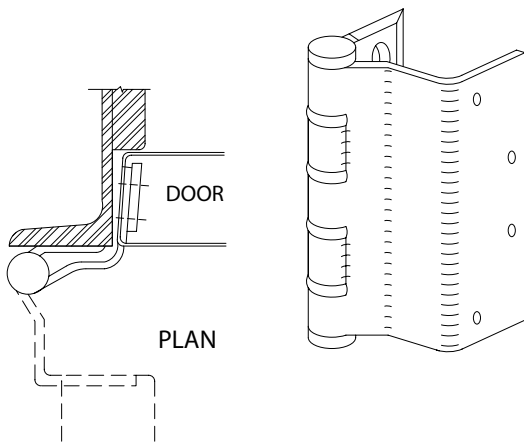

FIGURE 7b
HALF MORTISE

2. The Half Mortise Hospital Hinge, Figure 7b, has one leaf mortised into the door edge and one leaf surfaced-mounted on the frame face.

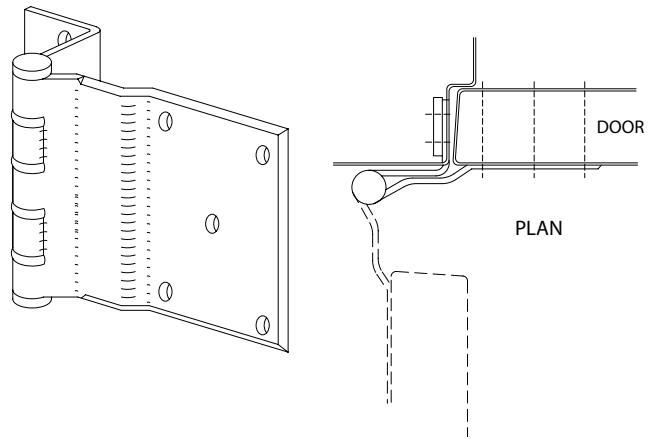

FIGURE 7c
HALF SURFACE

3. The Half Surface Hospital Hinge, Figure 7c, has one leaf surface-mounted on the door face and one leaf mortised into the frame rabbet.

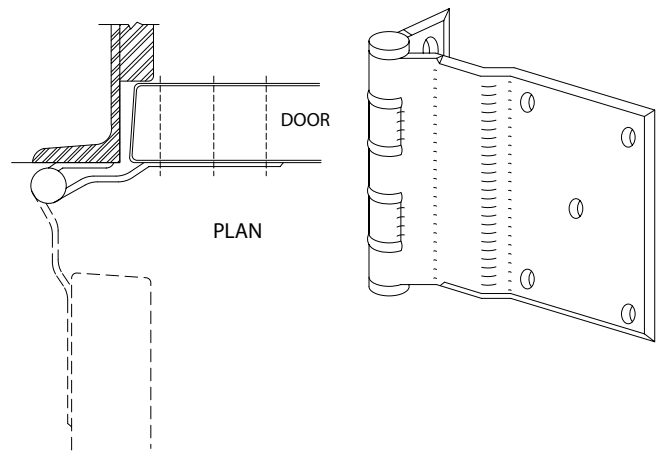
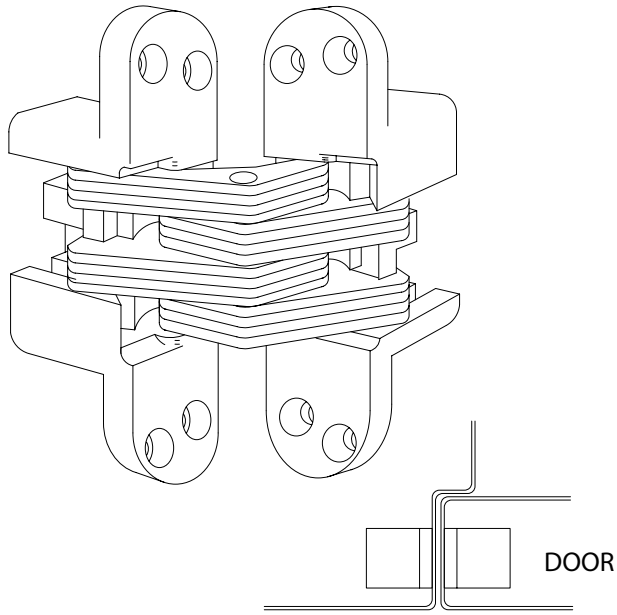

FIGURE 7d
FULL SURFACE

4. The Full Surface Hospital Hinge, Figure 7d, has one leaf surface-mounted on the door face and one leaf surface-mounted on the frame face.



PLAN

FIGURE 8
INVISIBLE HINGE

H. INVISIBLE HINGE

The Invisible Hinge, Figure 8, is fully mortised, centered on door thickness and is completely concealed when the door is closed.

PART 3 - SECURING DEVICES

A. LOCKS, LATCHES, AND DEADLOCKS

The locks shown here are those most commonly used. The names serve to identify either the type of lock construction or installation. Each may be provided with a knob or lever handle.

Mortise locks provide the greatest variety of lock functions, security, and have excellent durability. The cylindrical lock is the least secure type and is not available with a separate deadbolt in the lock. Another type is the preassembled unit lock.

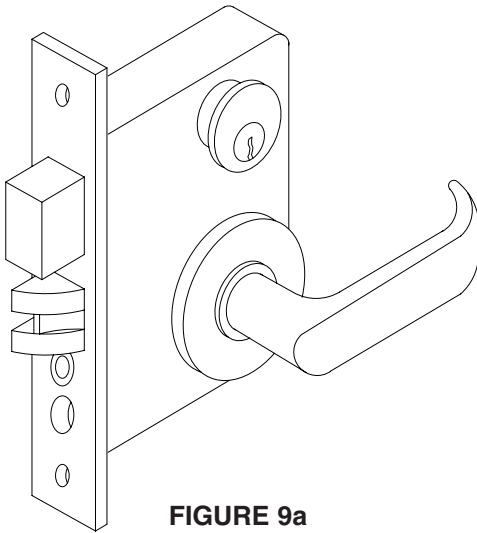

FIGURE 9a
MORTISE LOCK

1. The Mortise Lock, Figure 9a, is installed in a prepared recess (mortise) in the door. Working parts are contained in a rectangular case with holes for cylinder and spindle. Anti-friction split bolts are available for smooth retraction of the lock bolt. The lock front may be armored to protect cylinder screws and lock fasteners against burglars. Trim may be either sectional or escutcheon.

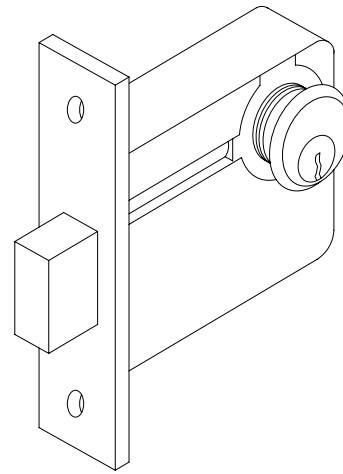

FIGURE 9b
MORTISE DEADLOCK

2. The Mortise Deadlock, Figure 9b, is a mortise lock with a deadbolt only. (A deadbolt is a lock bolt which has no bevel or spring action and is operated by a key or turn piece.) It is often used for locking a door having push or pull plates or for providing added security on doors with cylindrical locks.
3. The Cylindrical Lock, Figures 9c and 9d, has the cylinder through the knob or lever. The assembly must be tight on the door without excessive play to avoid binding.

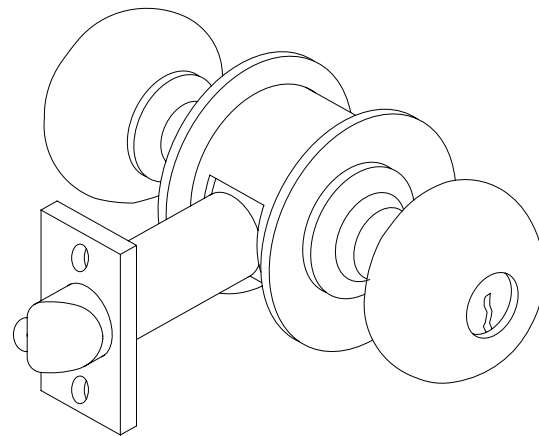

FIGURE 9c
BORED CYLINDRICAL LOCK

- 3a. The Bored Cylindrical Lock, Figure 9c, is installed in a door having one hole through the thickness of the door and another in from the edge.

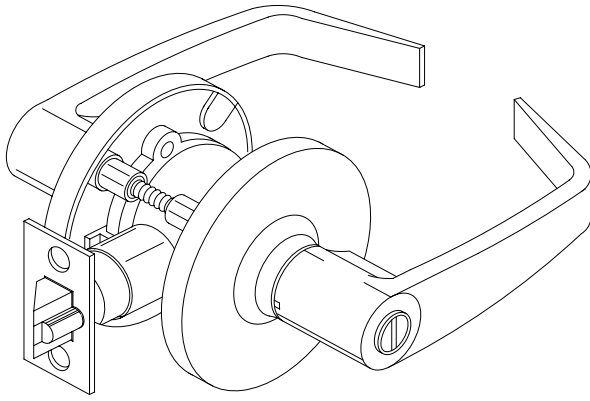

FIGURE 9d
THRU-BOLTED

3b. The Thru-bolted Cylindrical Lock, Figure 9d, requires two additional holes in addition to the preparation for the bored lock to prevent twisting of the lock body.

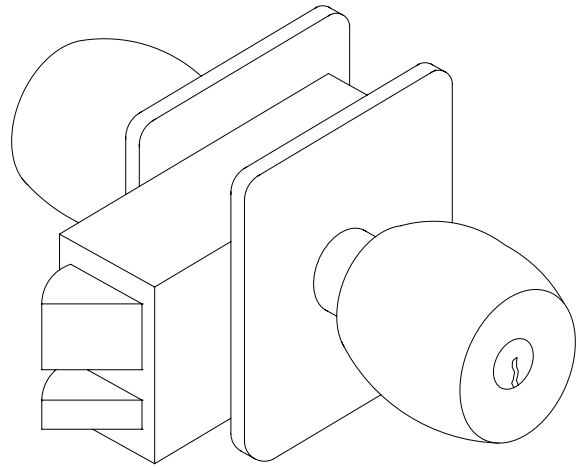

FIGURE 9f
UNIT LOCK

5. Unit Locks, Figure 9f, have all parts factory pre-assembled as a unit. They are thru bolted in a rectangular notch cut in the door edge and require little or no disassembly.

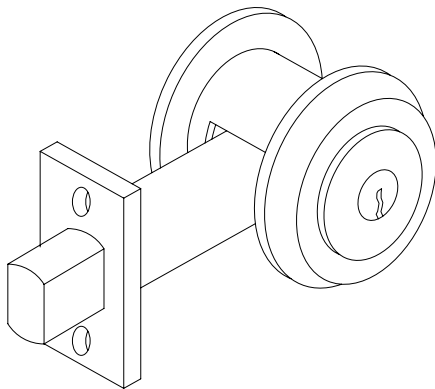
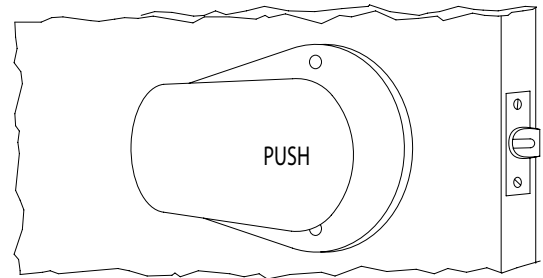
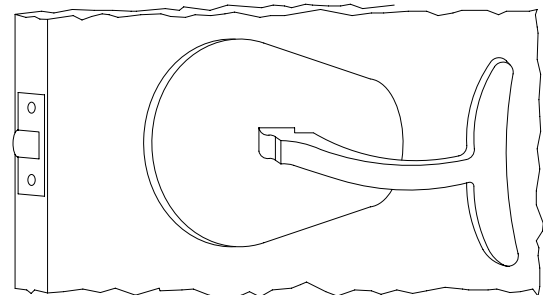

FIGURE 9e
BORED CYLINDRICAL DEADLOCK

4. The Bored Cylindrical Deadlock, Figure 9e, has only a deadbolt. It fits into the same type of cylindrical cutout as that required for the cylindrical lock. It may be operated with a key or a thumb piece.



PUSH SIDE



PULL SIDE

FIGURE 9g
HOSPITAL LATCH

6. The Hospital Latch, Figure 9g, originally designed for corridors to patient rooms in hospitals, may be used on any door requiring push-pull operation. It is particularly good for pushing or grasping by forearm or elbow, when hands are engaged in carrying objects.

B. PANIC / FIRE EXIT HARDWARE

Panic hardware is tested and labeled for life safety only, whereas fire exit hardware is tested for both life safety and fire resistance. Only the latter may be used where fire-rated doors are required. Both types are always operable from the inside by depressing a cross bar. The mortise type and the concealed vertical rod type are the least conspicuous, and are readily applicable to custom-hollow metal doors.

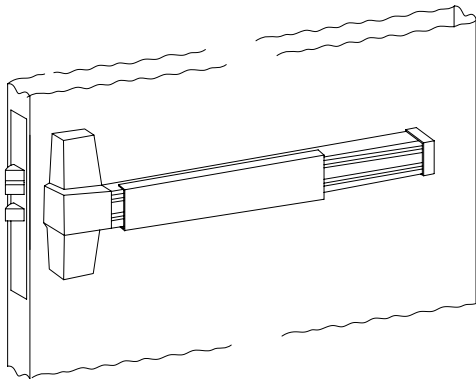

FIGURE 10a
MORTISE

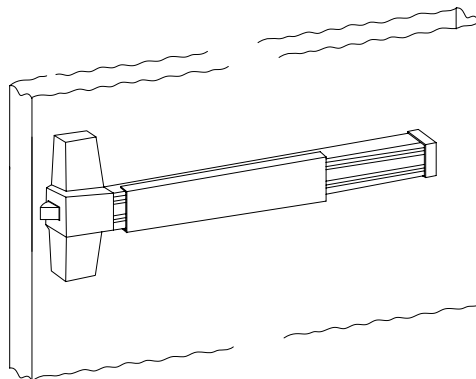

FIGURE 10b
RIM

1. Mortise, Figure 10a, and Rim, Figure 10b, types are used on single doors, active leaves of pairs, and multi-opening assemblies.

Where rim type or exposed surface vertical rod exit devices are specified, internal reinforcement plates shall be provided in the door and frame by the manufacturer. Drilling and tapping for trim and mounting plates shall be done in the field by the installer. The hardware can then be more readily adjusted for optimal operation.

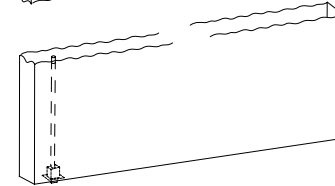
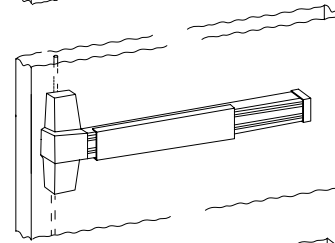
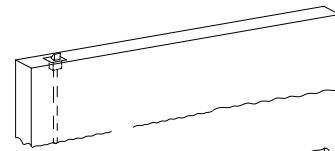

FIGURE 10c
CONCEALED VERTICAL ROD

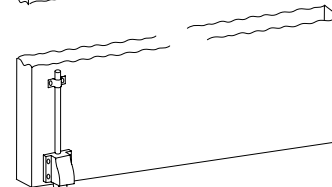
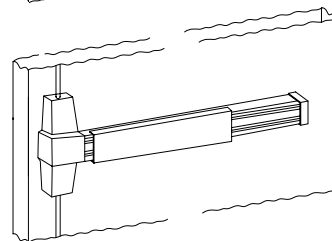
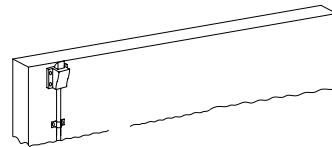

FIGURE 10d
SURFACE VERTICAL ROD

2. Vertical Rod types; (Concealed Figure 10c, and Surface, Figure 10d;) are normally used on pairs of doors. In preparing the door for an exit device, the drilling of the bolt holes (1/2 in. dia. or less) and/or the drilling and tapping for sectional or full trim plates shall be done in the field by the installer. After the lock is installed and adjusted, the trim plate can be applied to suit the final position of the latching device. If through bolt or tapped holes were provided by the manufacturer, this adjustment becomes difficult if not impossible.

Careful consideration must be taken in the selection of strikes and adjustment of rods to ensure proper operation.

C. BOLTS

These bolts are used on the inactive leaf of a pair of doors or a dutch door leaf to secure it in the closed position. They may also be used as an auxiliary locking device for added security. Bolts may be either flush (concealed rod) or surface mounted;

Generally these types of bolts should be used on doors that are intended to serve as emergency exits. NFPA 80, Standard for Fire Doors and Fire Windows, should be consulted for the selection of bolts for fire-rated pairs of doors.

1. Flush Bolts. There are many variations of flush bolts, only the more common types being shown here. Due to the variety of frame construction encountered, the selection of the most appropriate type of strike is particularly important, and clearance at the floor must be very carefully controlled to ensure proper engagement.

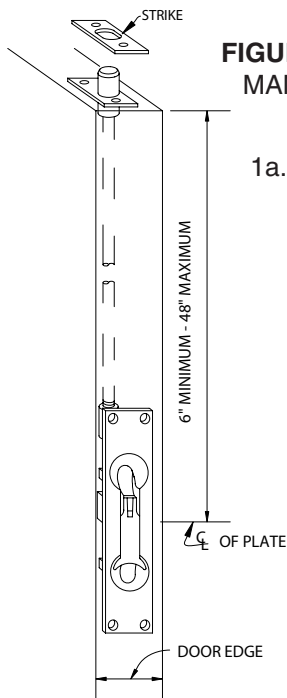

FIGURE 11a
MANUAL

- 1a. Manual Flush Bolts, Figure 11a, require hand operation of the lever for both latching and unlatching.

The various lengths of the extension rod permit convenient location of the operating mechanism in the door edge.

FIGURE 11b
SELF-LATCHING

- 1b. Self-Latching Flush Bolts, Figure 11b, operate automatically when the inactive leaf is closed, but must be unlatched manually.

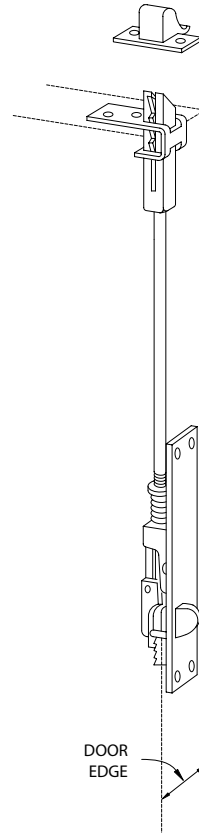
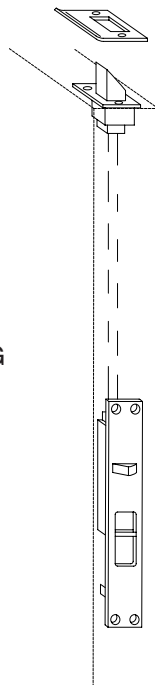

FIGURE 11c
AUTOMATIC

- 1c. Automatic Flush Bolts, Figure 11c, operate when the active leaf is opened or closed.

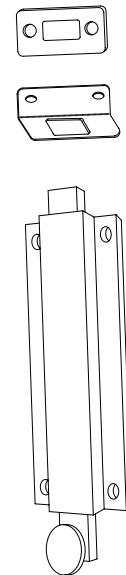

FIGURE 12
SURFACE

2. Surface Bolts, Figure 12, require manual operation for both latching and unlatching. They may be placed at the top or bottom of door.

PART 4 - CLOSING AND CONTROLLING DEVICES

A. CLOSERS

Closer devices control the closing of a door. They are available in a range of sizes for various door sizes, locations, and job conditions. The hardware manufacturer's recommendations should always be followed in determining size and type.

Where surface mounted closers or concealed components are specified, internal reinforcement plates are provided in the door and frame by the hollow metal manufacturer. Drilling and tapping shall be done in the field by the installer. Only after the door is installed and adjusted can the closer be mounted for proper operation.

AT NO TIME SHOULD A CLOSER BE USED AS A STOP, UNLESS THIS DEVICE HAS BEEN ENGINEERED TO INCLUDE SELECTIVE HOLD-OPEN, POSITIVE STOPS, OR BACK CHECK FEATURES.

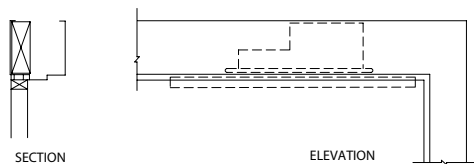
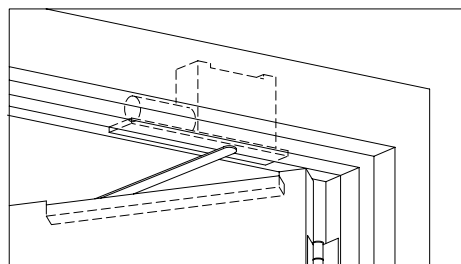
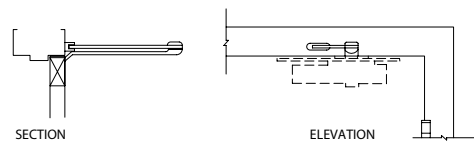
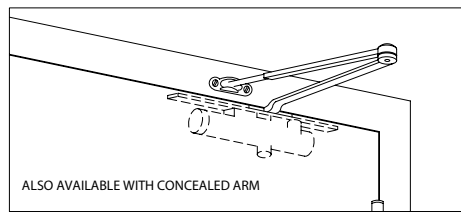
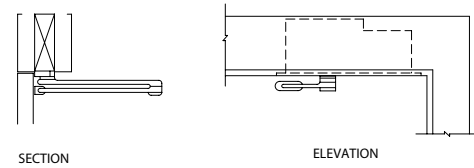
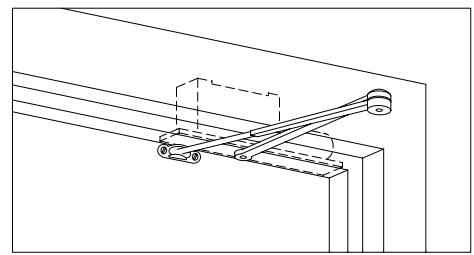
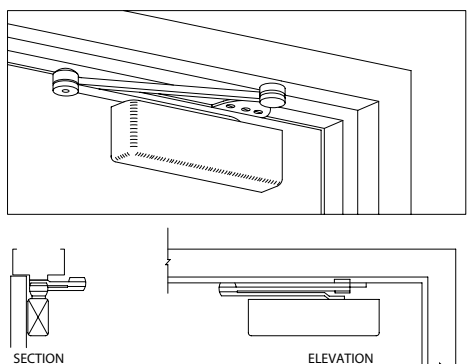
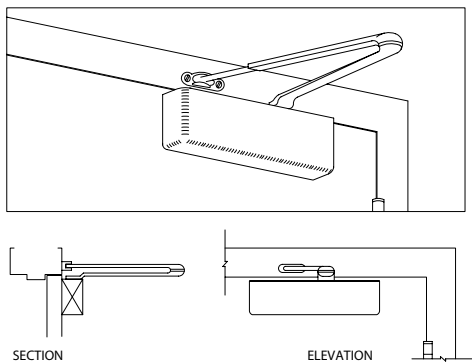

FIGURE 13
OVERHEAD CLOSERS

1. Overhead Closers, Figure 13, are hydraulic devices containing a piston, fluid chambers, and a spring. When the door is open the piston is pulled back, compressing the spring and moving the fluid from one side of the piston to the other. With the release of the door a reverse action takes place, closing the door. Closing speed is controlled by an adjustment valve or valves. Overhead closers may be concealed or surface mounted.

As shown, the type of closer used depends on whether the door is hung on hinges, offset pivots, or center pivots.

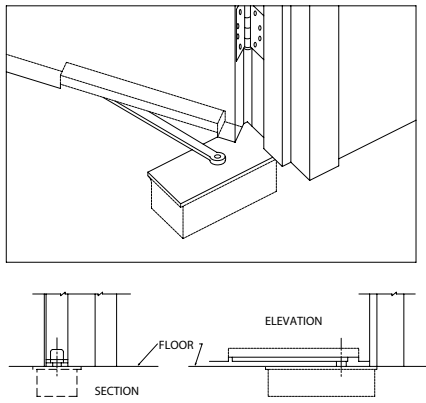

FIGURE 14a
FOR HINGED DOORS

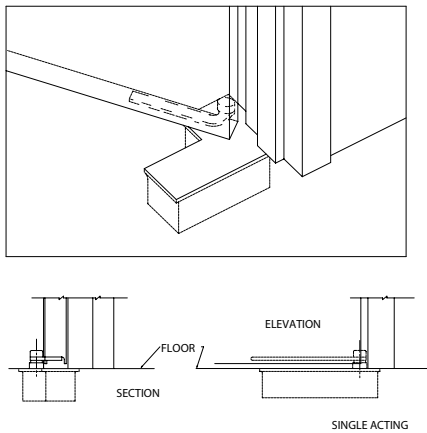

FIGURE 14b
FOR OFFSET PIVOT DOORS

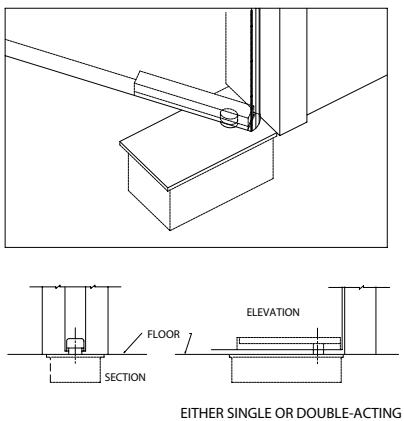

FIGURE 14c
FOR CENTER PIVOT DOORS

2. Floor Closers, Figures 14a-14c, generally are more durable than overhead closers and provide concealed closing mechanisms, often appropriate for doors having a high frequency of use.

B. DOOR COORDINATORS

Coordinators are used on pairs of doors. When both leaves are open, the coordinator holds the active leaf open until the inactive leaf is closed, preventing interference of the astragal or locking mechanism.

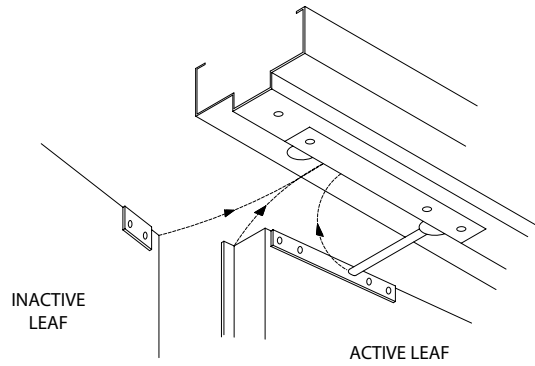

FIGURE 15a
MORTISE

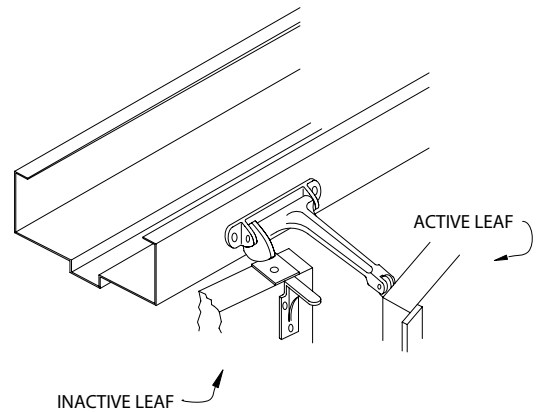

FIGURE 15b
SURFACE

PART 5 - STOPS AND HOLDERS

A. DOOR STOPS

Door stops prevent the movement of a door past a given point. They are just as important to the overall performance as hinges and locks. By controlling the amount of door movement, they serve to protect against damage, not only to the adjacent walls and equipment, but also the door, frame, and hardware.

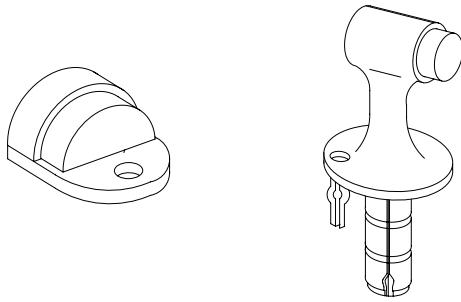

FIGURE 16a
FLOOR



FIGURE 16b
WALL

1. Floor Door Stops, Figure 16a, and Wall door stops, Figure 16b, are positive stops, mechanically attached to either the floor or wall. When the door is opened to the desired limit, it comes in contact with the stop which prevents any further travel.
2. Overhead Stops, Figure 16c and 16d, may be either concealed or surface applied, located at the top of the door with an arm connected to the head. These also limit the degree a door may be opened. Unlike the positive stop, this device has a shock absorbing spring which cushions the stopping action of the door, usually between 85 and 110 degrees.

WHEN USING OVERHEAD STOPS, THE MAXIMUM DEGREE OF OPENING MUST BE SPECIFIED.

Although special overhead closers and holders are engineered to include features of an overhead stop, they may be specified with a dead-stop feature.

Standard closers and or holders should not be used in lieu of an overhead door stop, which will result in premature failure of the door, frame and/or hardware components.

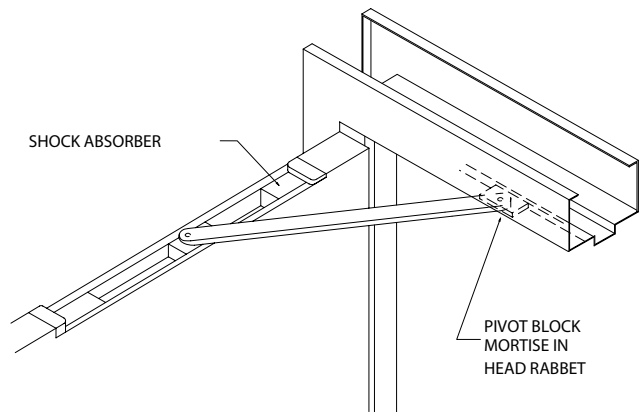

FIGURE 16c
CONCEALED

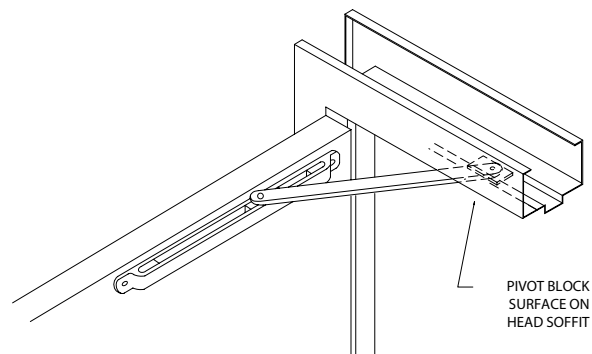

FIGURE 16d
SURFACE

B. EMERGENCY DOOR STOPS

Emergency Door Stops, Figure 17, are intended primarily for use in hospitals, on doors between patient rooms and bathrooms. This stop permits doors to be opened from the stop side in the event that an patient became incapacitated and blocked the door. The door must be hung on center (double acting) pivots.

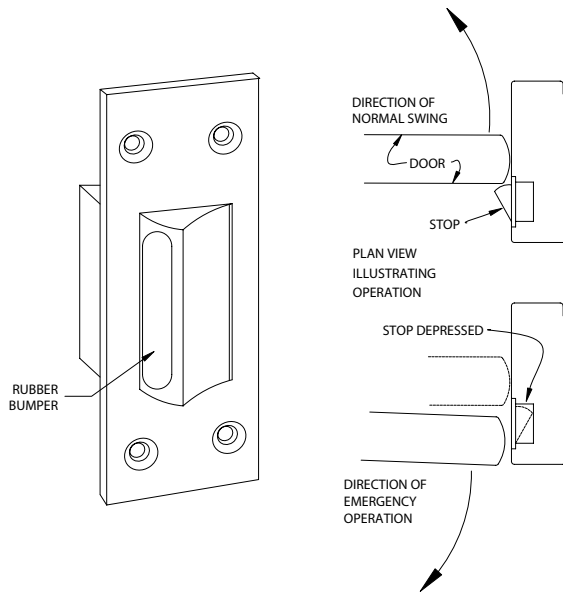

FIGURE 17
EMERGENCY RELEASE

C. OVERHEAD DOOR HOLDERS

Overhead door holders, Figure 18a and 18b, are devices used to hold the door in the open position.

AT NO TIME SHOULD A HOLDER BE USED AS A STOP, UNLESS THIS DEVICE HAS BEEN ENGINEERED TO INCLUDE SELECTIVE HOLD-OPEN, POSITIVE STOPS, OR BACK CHECK FEATURES.

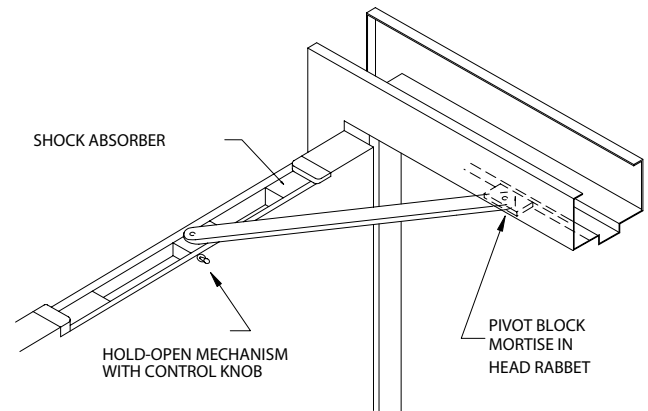

FIGURE 18a
CONCEALED

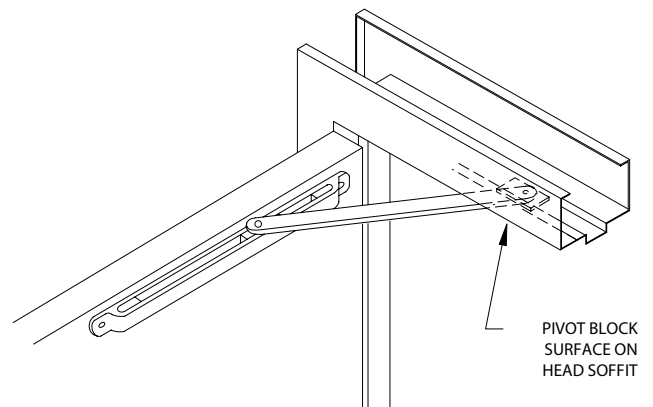

FIGURE 18b
SURFACE

PART 6 - MISCELLANEOUS

A. GASKETING/WEATHER-STRIPPING

The weather-stripping of today is far more advanced than in previous years. In the past, spring bronze was typically used as a weatherstripping around doors. Today's design and material advancements such as felt, vinyl, nylon, neoprene, and silicone enable the retardation of sound and smoke as well as climate control. With these advancements, a more appropriate term in lieu of weather-stripping is gasketing. Two types and styles of gasketing material and typical application are shown in Figure 19. For additional information contact your hardware consultant.

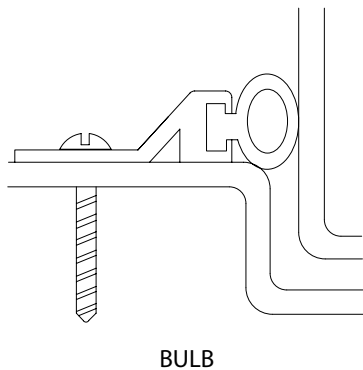
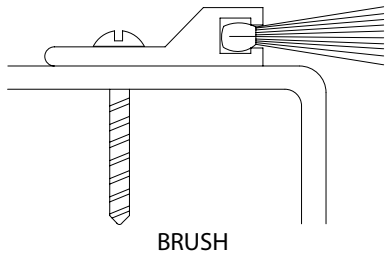

FIGURE 19

B. DOOR BOTTOMS

Door bottoms operate automatically when the door is closed sealing the bottom of the opening. This prolongs the life of the gasketing material, where as conventional sweeps constantly rub against the floor.

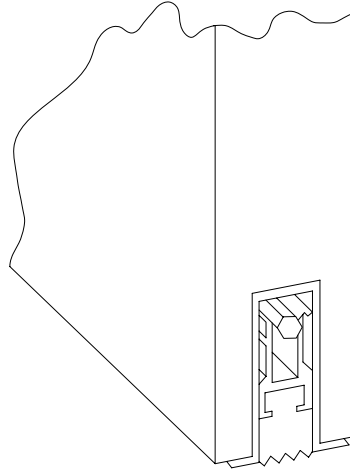

FIGURE 20a
MORTISE

1. Mortise Door Bottoms, Figure 20a, are set within a prepared recess in the bottom of the door. Since it is hidden within the door, the appearance of this is aesthetically pleasing.

Mortised door bottoms can not be used in conjunction with concealed Vertical Rods or Flush Bolts.

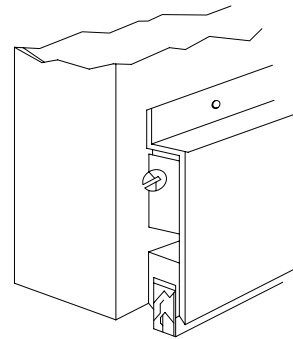

FIGURE 20b
SURFACE

2. Surface Door Bottoms, Figure 20b, are mounted to the surface of the door.

Surface door bottoms can not be used with surface vertical rods or bottom surface bolts.

NOTES

NOTES
